

 **Totalcomp, Inc.**

the weigh you want... *today!*

# TC-Series

## Service Manual

13-01 Pollitt Drive, Fair Lawn, NJ 07410

Phone: 201-797-2718 / Fax: 201-797-2287

## CHAPTER 1 GETTING STARTED

1-1 Package contents -----	1
1-2 Your TC series scale -----	1
1-3 Preparation -----	2
1-4 Option module & battery box -----	2

## CHAPTER 2 SET UP

2-1 Calibration-----	3
2-2 Parameters -----	7
2-3 In-house service mode -----	14
2-4 Printer connection-----	15
2-5 Relay connection-----	17
2-6 Numeric and alphabetic characters displayed on LCD -----	18

## CHAPTER 3 TC–DUAL CHANNELS (TC-220 & TC-292)

3-1 Introduction-----	19
3-2 Set Up -----	20

## CHAPTER 4 MAINTENANCE

4-1 Replacing printed circuit board -----	29
4-2 Replacing load cell -----	33

## CHAPTER 5 TROUBLESHOOTING

5-1 Preliminary checks -----	34
5-2 Error messages -----	34
5-3 Problems and solutions-----	35

## CHAPTER 6 SPARE PARTS & ACCESSORIES

5-1 TC series -----	38
---------------------	----

## CHAPTER 1 GETTING STARTED

### 1-1 Package contents

1. Scale body
2. Stainless steel weighing pan
3. Power cord
4. User manual
5. Option module (optional)
6. Sealing accessories (if needed)

### 1-2 Your TC scale (TC-200 series illustrated here)

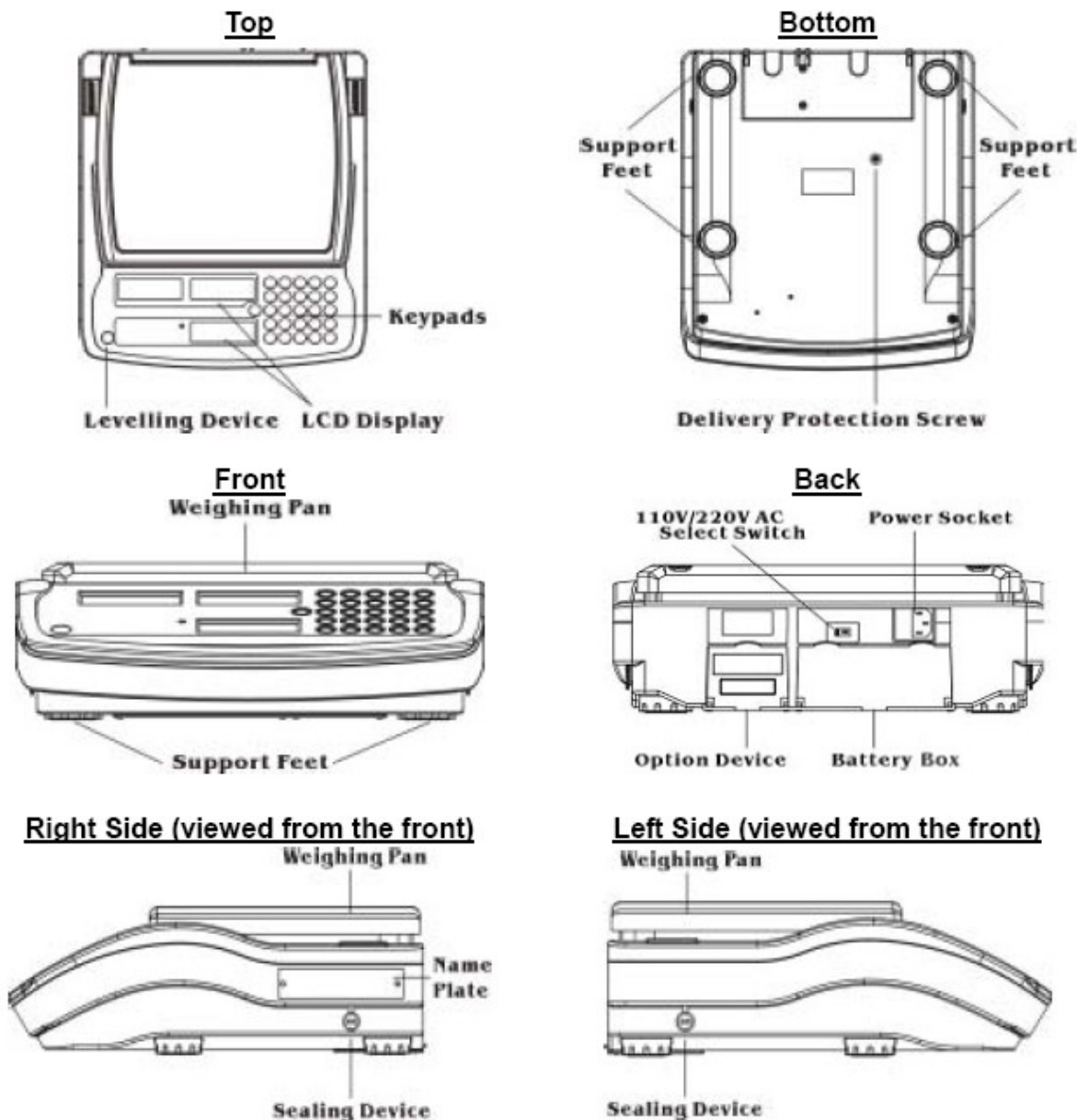

## 1-3 Preparation

**Note ! : Prior to use**

*Disassembly the delivery protection screw prior to use.  
Check whether power supply select switch is set correctly.*

1. Refer to the “bottom view” diagram in the previous section for the location of **delivery protection screw**.
2. Prior to use, always, counter-clockwise loosen the screw to the end.
3. Prior to delivery, always, clockwise tighten the screw to the end.
4. Refer to the “back view” diagram in the previous section for the location of **power supply select switch**. Check whether its setup meets your need.

## 1-4 Option module & battery box

1. At the rear side of the scale body, there are battery box and the option device module. The option module **can be either** of relay or RS-232/RTC.
2. Both the option device module and the battery box can be removed from the scale body **simply with hands**, for replacement and/or maintenance purpose. Refer to the diagram below.

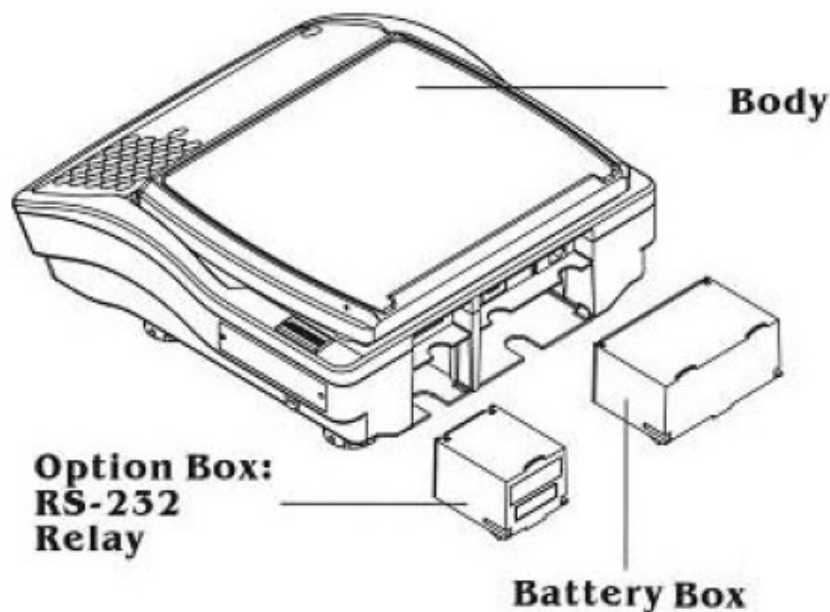

## CHAPTER 2 SET UP

### 2-1 Calibration

**Note ! : Metrological controls and/or regulations**

*The regulations and/or metrological controls governing to conduct calibration vary from country to country.*

*Please do follow the local metrological controls and/or regulations imposed by the local authority.*

On the **display PCB**, **jumper JP4** is to determine the ON/OFF of the calibration function, as shown below:





	Jumper JP4
To enable calibration:	Open-circuited
To disable calibration:	Shorted

#### ◆ TC-200 series three-point calibration



Follow the procedure below to conduct three-point calibration.

- To enter the **calibration mode** is the first step. (Within the calibration mode, if needed, press  to return to the initial step of calibration process.)

- Switch off the scale.

- Press  and  together, and then release  before . **ZERO** will be displayed in UNIT WEIGHT.



4. Press , **CAL-0** will flash indicating zero calibration in process. After completion, scale will beep and **CAL-1** will be displayed.
- CAL-1
- 00005G
5. Put on the first-point calibration weight. If the weight shown at TOTAL COUNT is not correct, to use number keys to key in the correct one. (2kg illustrated, for example)
- CAL-1
- 00025G
6. Press , **CAL-1** will flash indicating in process. After completion, scale will beep and **CAL-2** will be displayed.
7. Put on the second-point calibration weight. If the weight shown at TOTAL COUNT is not correct, to use number keys to key in the in the correct one. (4kg illustrated, for example).
8. Press , **CAL-2** will flash indicating in process. After completion, scale will beep and **CAL-3** will be displayed.
- CAL-2
- 00045G
9. Put on the third-point calibration weight. If the weight shown at TOTAL COUNT is not correct, to use number keys to key in the in

the correct one. (6kg illustrated, for example).

10. Press , **CAL-3** will flash indicating in process. After completion, scale will beep and **PASS** will be displayed at TOTAL COUNT. Calibration is completed. Switch off and then followed by switch on back to the normal weighing mode.



11. In the calibration mode, by pressing  the calibration weight used in the calibration can be seen.

W-1 : the first point calibration's value  
(2kg illustrated)



W-2 : the second step calibration's value  
(4kg illustrated)

































W-3 : the third step calibration's value  
(6kg illustrated)



◆ **TC-210 series three-point calibration**



Follow the procedure below to conduct three-point calibration.







1. To enter the **calibration mode** is the first step. (Within the calibration mode, when needed, press  to return to the initial step, and press  to return to the normal weighing mode.)
  2. Switch off the scale.
  3. Press  and  together, then release  before .
- After  displays, to release 
4. Leave the weighing pan empty, press .  will be displayed. 
  5. To conduct first point calibration. Put the first calibration weight onto the weighing pan. (For example, 2kg illustrated.)  will be shown. If the weight is not correct, use  or  to select. 
  6. Press  to conduct the calibration, and go to the second-point calibration.
  7. Put the second calibration weight onto the weighing pan. (For example, 4kg illustrated.)  will be shown. 
  8. Press  to conduct the calibration, and go to the third-point calibration.
  9. Put the third calibration weight onto the weighing pan. (For example, 6kg illustrated.)  will be shown. 
  10. Press ,  and    will be shown. Calibration is then completed.    
  11. If to see the calibration weight for the respective 3 points is intended, press  to observe the 3 different points' values.
  12. Switch off and then followed by switch on back to the normal weighing mode.

## 2-2 Parameters and the advanced parameters setting

TC series have two kinds of parameters – (ordinary) parameters and the advanced parameters. The advanced parameters are more related to the characteristic of weighing. The values of the advanced parameters should only be adjusted to fit certain particular applications, for having better weighing performance.

### ◎ To enter the parameter setting mode

In normal weighing mode, press  for 3 seconds (for **TC-200**), or  3 seconds (for **TC-210**), to enter **the Parameter Setting Mode**.

- Press  or  for scrolling up or down to the parameter intended to set.
- Press  or  to set each parameter's value.
- Press  (for TC-200), or  (for TC-210), for saving and meanwhile entering normal weighing mode.

### ◎ (Ordinary) parameters

The effects and setting of (ordinary) parameters are described as following:

#### P-0: Auto power-off time

Message shown :	counting scale : PowEr; <b>(weighing scale: PoW oFF)</b>
Selectable settings :	Off/10/20/30/40/50/60/70/80/90 minutes
Effect & Setting :	This parameter is to set the time period (in minutes) the scale will be turned off automatically, when after that no object on the scale.
Ex-factory set value:	Off (auto power-off function is disabled)

#### P-1: Backlight

Message shown :	counting scale : bACkL; <b>(weighing scale: bKL SAve)</b>
Selectable settings :	Off/on/Auto (applicable to TC-200) Off/on/Auto/Save (applicable to TC-210) Save : Off automatically, given 5 seconds after stable weighing
Effect & Setting :	This parameter is to set the on/off of display backlight
Ex-factory set value:	Auto (backlight is actuated when weight loading is over 20e)

**P-2: Serial number display**

Message shown :	counting scale : n-diS; <b>(weighing scale: Sno oFF)</b>
Selectable settings :	Off/on
Effect & Setting :	If this parameter's value is "on", the serial number set will be shown in TOTAL COUNT window when no weight loading on the pan. (When switch off the scale, the last serial number just before switch-off will be saved. Therefore, for label printing the number will be consecutive, regardless switch-off and then switch-on.)
Ex-factory set value:	Off (serial number is not shown)

**P-3: Beep sounding**

Message shown :	counting scale : bEEP; <b>(weighing scale: bEP)</b>
Selectable settings :	In/oUt/E-in/E-oUt
Effect & Setting :	The effect of this parameter is to determine when to have beep sounding during Hi/Lo/OK checking. In : when checking is OK (by scale's buzzer) oUt : when checking is beyond Hi/Lo (by scale's buzzer) E-in : when checking is OK (by external buzzer, through optional relay module) E-oUt : when checking is beyond Hi/Lo (by external buzzer, through optional relay module)
Ex-factory set value:	In

**P-4: Average ACAI (Automatic Counting Accuracy Improvement)**

Message shown :	counting scale : AvG-r; <b>(Not applicable to weighing scale)</b>
Selectable settings :	5/10/15/20/25/30/35/40/45/off
Effect & Setting :	ACAI is used to improve counting accuracy by automatic averaging. (See below for detail) 5 : Means <u>+ – 5% deviation</u> . (Within a group composed of the same object, if there is an object of which weight is + – 5% deviated from the unit weight, the scale will not conduct counting averaging. 10 : Means <u>+ – 10% deviation</u> . ..... 45 : Means <u>+ – 45% deviation</u> . Off : No restriction on the deviation of object's weight within a group of the same object.
Ex-factory set value:	Off

- \* ACAI (Automatic Counting Accuracy improvement) :  
A function for improving the accuracy in counting. In practice, not every single item is with the same exact weight within a group of the same objects. And therefore, which causes minor error in counting. ACAI is a function to deal with this kind of circumstances.
- \* Procedures to activate ACAI function:
  1. In the normal weighing mode, put at least 10 pieces of the same object on the weighing pan. *(For example, 10 said pieces are put onto.)*
  2. Key in the number of pieces put by numeric keys. *(For example, "10" is key in.)*, And then press **SMPL** key. (The lighted-up ACAI indicator on the LCD display indicates ACAI function is actuated.)
  3. Put the same type of object onto the weighing pan. The number of pieces put this time **MUST** be smaller than that already on the weighing pan. Beep sound indicates ACAI is actuated. *(For example, in the first time 10 pieces were put onto. This second time the largest number of pieces can be put is 9. At the third time, the largest number of pieces can be put is 18, if at the second time 9 pieces were put onto.)*
  4. Repeat the step 3 few times. The more times to repeat, the more accurate the pieces counting will be.

Remark:

1. To activate ACAI function, every time the number of pieces put onto should be **grater than 5**.
2. When power is off, ACAI data is NOT memorized. Re-do ACAI function is needed after every power on.
3. When weighing unit or object to be weighed is changed, re-do ACAI function is needed.

#### P-5: Printer type

Message shown :	counting scale : Print; <b>(weighing scale: norMAL)</b>
Selectable settings :	Normal/EZ-2P/BP-343
Effect & Setting :	Setting of this parameter determines the data format for the connected printer type. Normal: SH-24 or compatible printers EZ-2P: EZ-2P printer bP-343: BP-343 printer
Ex-factory set value:	Normal

**P-6: Baud rate (RS-232)**



Message shown :	counting scale : bAUd; <b>(weighing scale: 9600)</b>
Selectable settings :	2400/4800/9600/19200
Effect & Setting :	Setting of this parameter determines RS-232 data transmission rate.
Ex-factory set value:	9600

**P-7: Data format (RS-232)**

Message shown :	counting scale : dAtA; <b>(weighing scale: n81)</b>
Selectable settings :	n81/o81/e81/n71/o71/e71
Effect & Setting :	Setting of this parameter determines the RS-232 transmission data format.
Ex-factory set value:	n81

**⊙ Advanced parameters setting mode**

In the Parameter Setting Mode,

- Press **GROSS/NET** key without releasing for about 3 seconds to **enter the advanced parameter setting mode**
- Press **M+** or **M-** key to go to the next advanced parameter
- Press **Hi** or **Lo** key to set the parameter's values
- Press  (for TC-200), or  (for TC-210), for saving and meanwhile entering the normal weighing mode
- These advanced parameters need only to be set for achieving better and/or particular weighing performance in certain applications. Besides this purpose, **do not** alter the ex-factory values of those parameters. The effects and setting of the advanced parameters are as following:

**AP-0: (only applicable to special printing purpose)**

How to identify (data shown on LCD) :	Counting scale: SPrt; <b>(weighing scale: SPrt 100)</b>
Selectable settings :	10 ~ 100
Effect & Setting :	The effect of this parameter is very complicated, which is only applicable to special printing circumstances. It is rare to use this parameter. <b>Pls just set this parameter to the ex-factory value 100.</b>
Ex-factory set value:	100

**AP-1: Filter (digital filtering)**

How to identify (data shown on LCD) :	Counting scale: FiLt; <b>(weighing scale: FiL 15)</b>
Selectable settings :	1 ~ 21 (odd numbers)
Effect & Setting :	The effect of this parameter is to filter signal glitch, so that the display will be more stable. Each level of set value is a trade-off between reacting speed and the effect to filter. 1 : no filter effect 3 : the least effect to filter 21 : the largest effect to filter
Ex-factory set value:	15

**AP-2: Stability of display**

How to identify (data shown on LCD) :	Counting scale: StAbL; <b>(weighing scale: Stb 3- 15)</b>
Selectable values :	To use Hi or Lo key to select one of the three digits to be set. Use <b>numeric keys</b> to directly key in the desired number. The first digit ranges 2 ~ 9 : for the number of times of data acquisition. The second and third digit ranges 00 ~ 99 : for the difference in internal resolution
Effect & setting :	The effect is to neglect environmental interference to affect the stability of display. For instance, 3-15 means to neglect the difference of 15 internal resolutions within 3 consecutive acquired data.
Ex-factory set value:	3-15

**AP-3: Minimum sensitivity**

How to identify (data shown on LCD) :	Counting scale: Min; <b>(weighing scale: Min 20)</b>
Selectable settings :	1 ~ 21 (in terms of "e")
Effect & Setting :	Set value here will determine the minimum weight to actuate the functions like printing, accumulation, and backlight ... etc.
Ex-factory set value:	20

**AP-4: Hysteresis**

How to identify (data shown on LCD) :	Counting scale: HyS; <b>(weighing scale: HyS 3)</b>
Selectable settings :	0 ~ 9
Effect & Setting :	The effect of this parameter is to treat with when the internal count data is around the display resolution changeover point. The larger the value is, the larger the changeover hysteresis

	band is. 0 : no any hysteresis effect 1 : the least effect of hysteresis 9 : the largest effect of hysteresis
Ex-factory set value:	3

**AP-5: Vibration-resistant**

How to identify (data shown on LCD) :	Counting scale: vibrA; <b>(weighing scale: vib 1)</b>
Selectable settings :	0 ~ 21
Effect & Setting :	The effect of this parameter is to resist environmental vibration to the platform where scale is on. 0 : no any vibration-resistant effect 1 : the least effect for vibration-resistant 21 : the largest effect for vibration-resistant
Ex-factory set value:	1

**AP-6: Zero tracking**

How to identify (data shown on LCD) :	Counting scale: Z-tAr; <b>(weighing scale: Ztr on)</b>
Selectable settings :	On & off
Effect & Setting :	on : to enable automatic zero-tracking function off : to disable automatic zero-tracking function <b>Pls set this parameter always to "on". "Off" is used only for certain testing purpose.</b>
Ex-factory set value:	On

**AP-7: Unit**

How to identify (data shown on LCD) :	Counting scale: Unit; <b>(Not applicable to weighing scale)</b>
Selectable settings :	Kg, lb, 1000 lb
Effect & Setting :	To set the weighing unit of the scale.
Ex-factory set value:	kg

**AP-8: Port**

How to identify (data shown on LCD) :	Counting scale: Port; <b>(weighing scale: Port 1)</b>
Selectable settings :	1 & 2
Effect & Setting :	1 : one RS-232 port 2 : two RS-232 ports (output to , for example, printer and PC.)
Ex-factory set value:	1

**AP-9: Bounce**

How to identify (data shown on LCD) :	Counting scale: boUnC; <b>(weighing scale: boU 2)</b>
Selectable values :	1 ~ 5
Effect & setting :	The number of mechanical bounces to neglect when pressing a certain key 1 : 1 bounce to neglect 5 : 5 bounces to neglect <b>Pls set this parameter always to “2”. Others are used only for certain testing purpose.</b>
Ex-factory set value:	2

**AP-10: ID lock**

How to identify (data shown on LCD) :	Counting scale: id-Lk; <i>(Not applicable to weighing scale)</i>
Selectable settings :	0, 1, 2
Effect & Setting :	This parameter determines whether or not the 50 sets of ID become read-only. 0 : not to lock 1 : to lock (50 sets of ID become read-only. That is, users can not change those 50 sets of ID..) 2 : the scale can ONLY be used as weighing scale. That is, there is no sampling or counting function any more.
Ex-factory set value:	0

**AP-11: A/D conversion gain (applicable to dual channel model only)**

How to identify (data shown on LCD) :	Ad
Selectable settings :	1, 2, 4, 8, 16, 32, 64
Effect & Setting :	The larger the number is, the larger the internal A/D conversion gain is.
Ex-factory set value:	2

**AP-12: Dual channel (applicable to dual channel model only)**

How to identify (data shown on LCD) :	duAL
Selectable settings :	Main, Sub, bothH
Effect & Setting :	Applicable to TC series dual channel model only. MAin : the weighing is performed at TC series scale Sub : the weighing is performed at the platform connected to TC series scale bothH : the weighing is performed at TC series scale and the









	<p>platform connected to TC series scale</p> <p><b>Note:</b> Once setting to either <b>Sub</b> or <b>bothH</b>, when power on the scale, the scale will NOT be in the normal weighing mode.</p> <p>Press  without releasing to switch on the scale in order to enter the parameter setting mode, and then press <b>Gross/Net key</b> to enter the advanced parameter setting mode to change this parameter to <b>Main</b> so that when power-on the scale will be in the normal weighing mode.</p>
Ex-factory set value:	MAin

## 2-3 In-house service mode

This is mode designed for in-house service persons. In this mode, service person can set the model/resolution, check eccentricity, conduct calibration, view the internal count value, conduct LCD display checking, and keypad checking.



### ◎ To enter the in-house service mode

Enter the in-house service mode by the procedure below:

1. While press  without releasing to switch on.  
Release  after seeing "id" is displayed.
2. For both **TC-200 & TC-210**, press the password of "   " in sequence to enter in-house service mode.
3. In this in-house service mode, press  only for entering to the next item.  
(Note that pressing  is with no any operation.)

### ◎ Set the model/resolution

TC series are built in with 30,000 divisions, for users convenience. Follow the procedures below to set the model/resolution.

1. Enter the **service mode**.
2. Press  or , to set the model. (Either one of 30kg/1g, 30kg/10g, 60kg/2g, 60kg/20g, 3kg/0.1g, 3kg/1g, 6kg/0.2g, 6kg/2g, 15kg/0.5g, or 15kg/5g)
3. Press  to go to the next setting item, i.e., offset value.

⊙ **Offset value**

1. For **TC-200**, internal offset value is shown in TOTAL COUNT window. As long as the internal offset value is in **positive** value, it is normal.
2. Press  to go to the next setting item, i.e., LCD check.

⊙ **LCD and keypad checking**

1. In this item, all segments and symbols will be lighted up for visual checking.
2. Press  to go to the next setting item, i.e., keypad check. “4” will be shown.
3. Press each key to check whether it is normal. A corresponding numeric number will be shown on LCD.
4. After completing all keys checking, switch off the scale, followed by switching on to enter the normal weighing mode.

**2-4 Printer connection**

⊙ **RS-232 data protocol**

**Output Data When Print Mode Set As Continue**

Case1: No unit weight on Scale

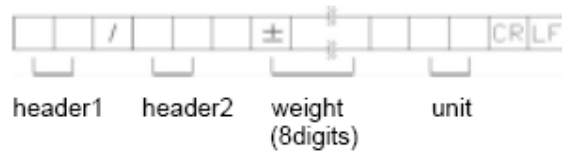

Case2: with unit weight on Scale

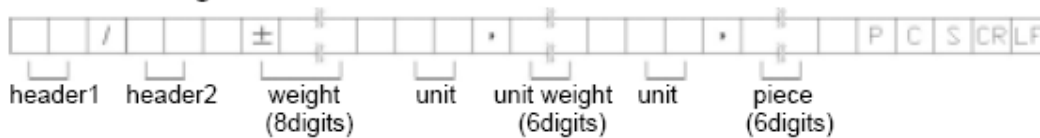

( header1: ST=STABLE US=UNSTABLE)

( header2: NT=NET GS=GROSS)

examples for Case1:

ST /NT□+□12.350□kg  
US/GS□+□30.000□lb

examples for Case2:

ST /NT□+□10.000□kg,1.0000□g, □10000□PCS  
US/GS□+□30.000□lb,0.0010□ lb, □30000□PCS

**Input Commands**

“T”=perform TARE function

“Z”=perform ZERO function

## ◎ To connect with printer/PC

### Scale To Printer

Connector for EZ-2P/BP-443D

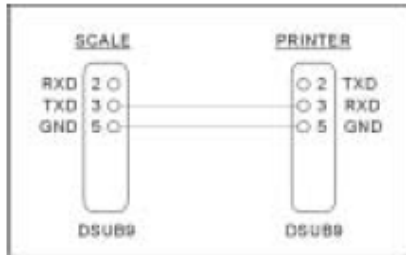

Connector for SH-24

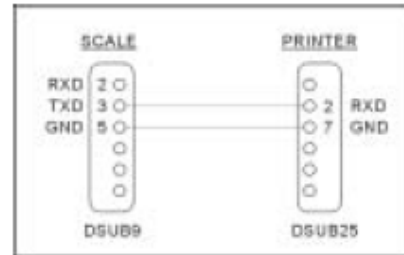

### Scale To PC

When you want a scale to transmit data to PC continuously.

- (1) Using a cable as following to connect Scale and PC
- (2) Set printer mode as continue
- (3) Scale data will be sent to PC continuously. (of course, you must have the receiving software on the PC)

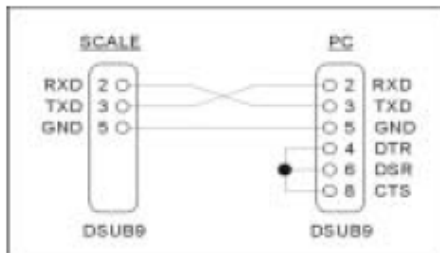

Only pin 2,3 and 5 are used.

TC series printer module is of RS-232 interface. Printer models of EZ-2P, BP-443D, and SH-24 are as standard accessorized printers with TC series. However, other general RS-232 printers that to be actuated without command codes can also be connected with TC series printer module for printing. Follow the procedures below for printer connecting.

## ◎ When connected to EZ-2P or BP-443D printer

1. Set Parameter P-5 of TC series, Printer Setting, which is to select printer type, to "**EZ-2P**" for EZ-2P printer, or to "**BP-443D**" for BP-443D printer. (Ex-factory P-5 setting is "**normal**".)
2. Set Parameter P-6 of TC series, Baud Rate Setting, which is data transmission rate, to "**9600**". (Ex-factory P-6 setting is "**9600**".)
3. Set Parameter P-7 of TC series Data Setting, which is transmission data format, to "**n81**". (Ex-factory P-7 setting is "**n81**".)
4. Initiate printing by pressing to **print** key.

◎ **When connected to printer other than EZ-2P or BP-443D**

1. General RS-232 serial port printer that is actuated to print without command codes can be connected to TC series for printing. Refer to your printer's user manual to know. If whether with or without command codes is unknown, simply connect the printer to the TC series for trial.
2. Set Parameter P-5 of TC series, Printer Setting, which is to select printer type, to "normal". (Ex-factory P-5 setting is "normal". This step can be ignored if there is no previous change in P-5.)
3. Set Parameter P-6 of TC series, Baud Rate Setting, which is data transmission rate, to the same as that of printer. (Ex-factory P-6 setting is "9600". This step can be ignored if your printer transmission rate is 9600 bps.)
4. Set Parameter P-7 of TC series Data Setting, which is transmission data format, to the same as that of printer. (Ex-factory P-7 setting is "n81". This step can be ignored if your printer data transmission format is n81.)
5. Initiate printing by pressing **to print** key for trial. If the settings of P-6 Baud Rate Setting and the P-7 Data Setting are set correctly, i.e., fit that of your printers, then if your printer is without command codes, printing will start. Otherwise, no printing will happen.

## 2-5 Relay connection





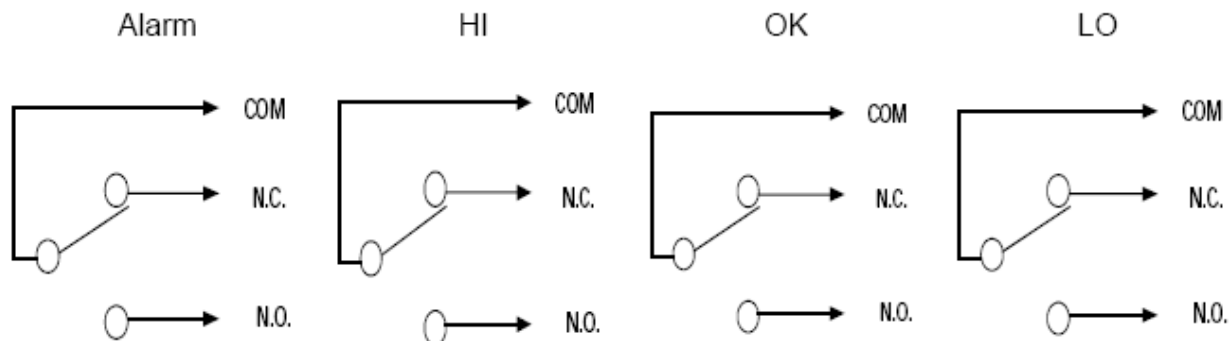































Optional relay module with TC series is available. The relay module is with four sets of contact outputs, as shown below.

**Relay Output :**



**Relay Contact Spec:** 1A/24VDC • 0.5A/125VAC • 0.25A/250VDC

## 2-6 Numeric and alphabetic characters displayed on LCD

0	1	2	3	4	5	6	7	8	9
									
A	B	C	D	E	F	G	H	I	J
									
K	L	M	N	O	P	Q	R	S	T
									
U	V	W	X	Y	Z				
									

## CHAPTER 3 TC –dual channels (TC-220 & TC-292)

### 3-1 Introduction

TC-dual channel is a derivative model of TC. TC-dual channel provides function to connect TC with an external weighing platform. The configuration may be as one of the following:

1. Both: To apply both TC series (main) and the remote platform (sub-channel)
2. Sub: To apply only the remote platform (sub-channel)
3. Main: To apply only the TC series itself (main)

#### ◎ Sub-Channel Specification

Input sensitivity :	1~4mV/V
Zero adj. Range :	20% FS
A/D conversion rate :	10 times per second.
Load cell excitation :	5V DC
Number of load cells :	up to 4x350 ohm load cells
Display resolution :	Up to 1/30,000

Diagram of sub channel connector

- |   |     |
|---|-----|
| 1 | E+  |
| 2 | E-  |
| 3 | S+  |
| 4 | S-  |
| 5 | GND |











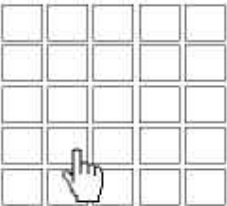

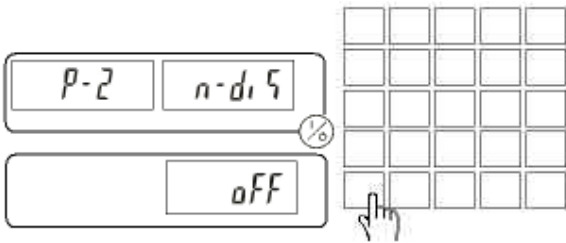

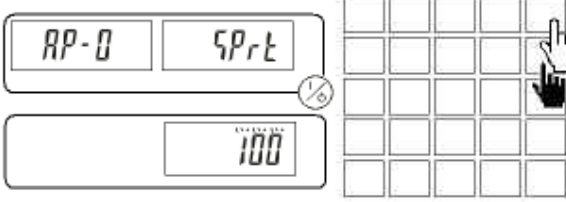
#### ◎ To install Sub-Scale (remote platform)

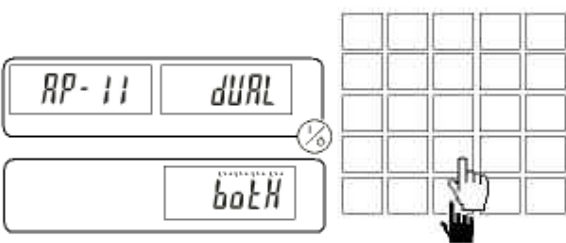

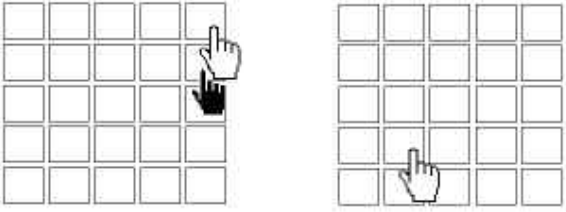







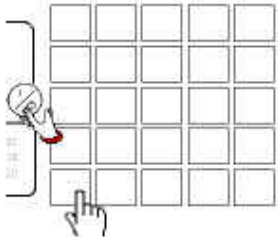



1. Turn off the scale.
2. Connect the Sub-Scale (remote platform) to the scale.
3. Set the advanced parameter Ap-12 to either “both” or “Sub”. (Refer to the Section of “set up” below)
4. Set the sub-scale maximum capacity and resolution. (Refer to the Section of “set max capacity & division of remote platform” below)
5. Set the advanced parameter Ap-11 to the right value, if it is needed. (Refer to item 6 of the Section of “set max capacity & Division of Remote Platform” and “set AD gain of remote platform” below)
6. Conduct three-point calibration both for main and sub-scale (Refer to the Section of “three-point calibration for main scale and remote platform” below)

### 3-2 Set Up

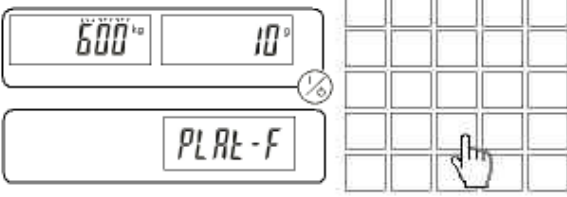
#### ■ Set The Parameters Correctly To Activate The Remote Platform

	<p>(1) Under normal weighing mode, press  for 3 seconds to enter the basic parameter settings.</p>
	<p>(2) The scale is now in the basic parameter setting mode. press  for 3 seconds to enter the advance parameter settings.</p>
	<p>(3) The scale is now in the advance parameter setting mode. Press  or  to switch between the parameters. Repeat step 3 until AP-11 appear</p>
	<p>(4) AP-11 will appear in the weight display. Press  or  to select between <i>both</i>, <i>Sub</i>, or <i>main</i>.</p> <p><i>both</i> means “ Using main scale and second platform together.”</p> <p><i>Sub</i> means “ Using second platform to weight and operate the main scale as indicator “.</p> <p><i>main</i> means “ Using main scale only.</p>
	<p>(5) Press  or  to save and go to next advanced parameter setting or press  to save the setting and return to normal weighing mode.</p>

## ■ Set max. Capacity & Division Of Remote Platform

	<p>(1) Switch off the scale. Press  and  together then release , but keep pressing  until <i>PLAŁ-F</i> appear in the total count display.</p>
	<p>(2) After <i>PLAŁ-F</i> appears in total count display, then you can set up the division of the second scale.</p>
	<p>(3) Set up the division by key in the desired division value.</p> <p>For example:</p> <p>Set division as 10g. Press  , then 10 will display in unit weight display and flash.</p>
	<p>(4) Press  key to switch to capacity setting.</p>
	<p>(5) Set up the capacity by key in the desired max. capacity value.</p> <p>For example:</p> <p>Set max. capacity as 300kg. Press    and the number 300 will appear in the weight display and flash.</p>

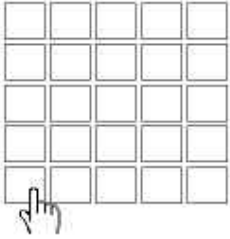

(6) Press  to save the capacity and division settings and automatically enter into the calibration mode.

Please refer to Three-point calibration for main scale and second platform to conduct the calibration. Please start with step (2).

**Note :**

Please remember the digits of the internal counts when you complete three-point calibration for second scale.

If the internal counts of the second platform are not close to the internal counts of the main scale, then please refer to “Set AD gain of second platform.”

For example:









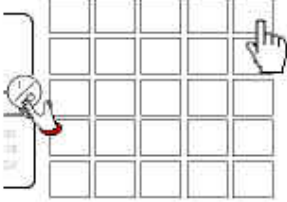

After completion of the 3-point calibration procedure for main scale and second platform, the internal counts for the main scale is 33, and the internal counts for the second platform is 4.



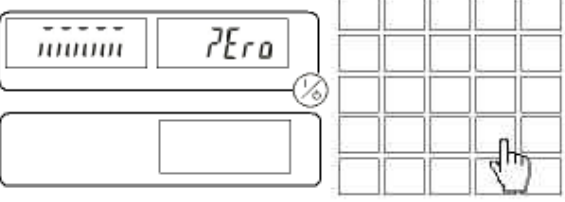



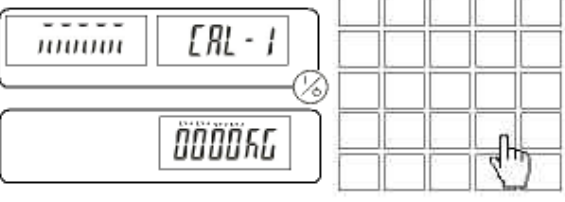



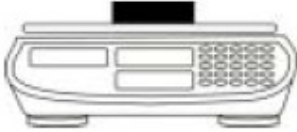

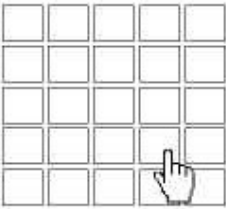
This means that the internal counts of the main scale is approximately 8 times higher than the internal counts of the second platform.

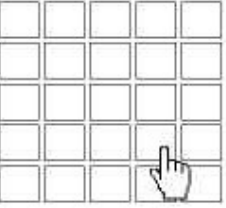

It means that the initial AD gain parameter should be multiplied 8 times. For example if the initial setting is 8 then you need to reset the AD gain parameter to 64.

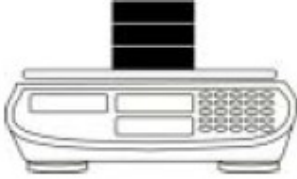
■ Three-Point Calibration For Main Scale And Remote Platform

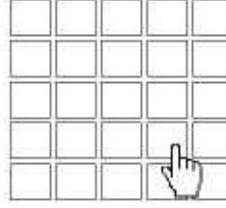



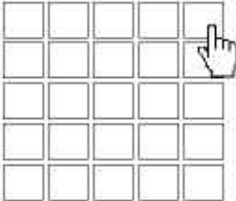





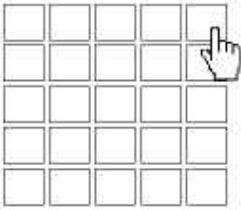

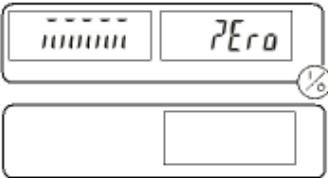

Note ! : Main scale should be calibrated first.

	<p>(1) Switch off the scale and then Press  and  together, then release  but keep pressing  key until <b>Zero</b> appear in the unit weight. Display.</p>
	<p>(2) Please conduct 3 point calibration.</p> <p>2-1  means three-point calibration for main scale.</p> <p> means three-point calibration for second platform.</p> <p>2-2. Press  to switch to three-point calibration for main scale or second platform.</p> <p><b>Important Note.</b> You can only do the 3-point calibration for the second platform after you have set the max. capacity and division for the second platform.</p> <p>Leave weighing pan empty and press  key to do the zero point calibration.</p>
	<p>(3) <b>CAL-1</b> appears in the unit weight display and the scale beeps. You can now do the 1-point calibration</p> <p>Note:</p> <p>If current unit is lb, the  will be replaced by </p>



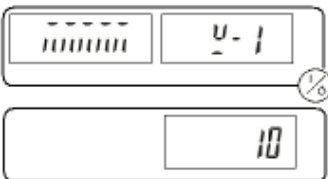

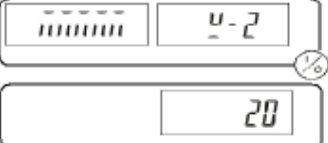
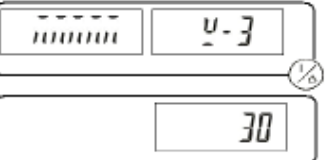
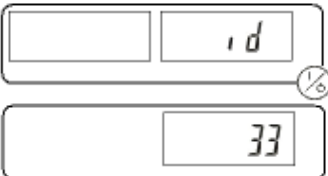





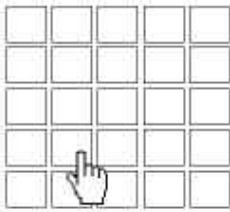

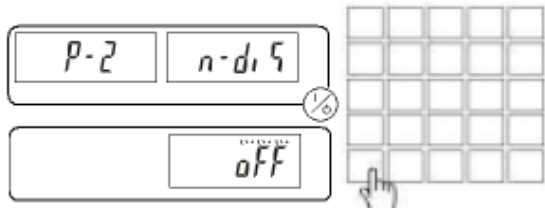

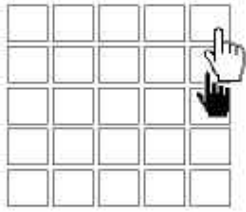
 	<p>(4) Put the first calibration weight onto the weighing pan. (For example, 10kg illustrated.) If the weight is not correct, key in the correct numbers by keys.</p>
 	<p>(5) Press  to perform the 1- <b>point calibration</b> and afterwards will <b>CAL-2</b> appear in the unit weight display and the scale will beep.</p>
 	<p>(6) Put the second calibration weight onto the weighing pan. (For example, 20kg illustrated.)</p>
 	<p>(7) Press  to conduct the <b>2 point calibration</b>. and afterwards will <b>CAL-3</b> appear in the unit weight display and the scale will beep.</p>
 	<p>(8) Put the third calibration weight onto the weighing pan.</p>
 	<p>(9) Press  to perform the 3-point calibration</p>

	<p>(10) <b>PASS</b> appear in the total count display and the scale will beep.</p> <p>(11) After three-point calibration for <b>main scale</b> is finished, please remember the digits, which appears the unit weight display.</p> <p>For example, the digits <b>33</b> shown in the unit weight display means “ 1division equals 33 internal counts.</p> <p>The closer division digits of main scale and second platform, the better performance of the system.</p>
	<p>(12) Press  to save the calibration, then the unit weight display and total counts display will show the three-point calibration weights for the respective 3 points.</p> <p>(13) Turn off and turn on the scale, now is OK to be weighing..</p>
<p>Note :</p> <p>You can press  to restart the calibration from the beginning during the three-point calibration procedures.</p>	

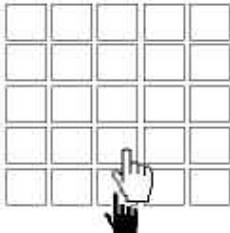

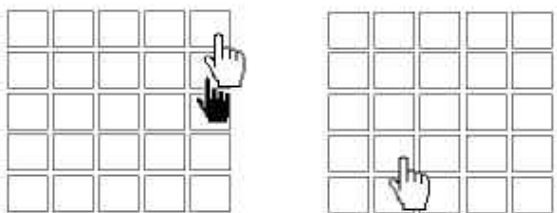







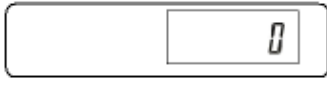

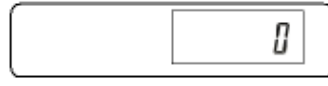

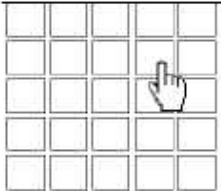

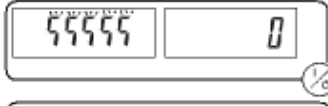
■ Call Up The 3-Point Calibration Data

	<p>(1) Switch off the scale and then Press  and  together, then release  but keep pressing  key, until <i>Zero</i> appear in the unit weight display.</p>
	<p>(2) After <i>Zero</i> appears,</p> <p>2-1  means three-point calibration for main scale.</p> <p> means three-point calibration for second platform.</p> <p>2-2. Press  to switch three-point calibration for main scale or for second platform.</p>
	<p>(3) Press  to call up the calibration data. The calibration data will automatically appear in sequence.</p>
	<p>(4) The left figure means 1<sup>st</sup> point calibration weight</p> <p>Note:   kg in the WEIGHT indicates that it's been calibrated with kg unit. It will show  when the last calibration is with lb unit.</p>
	<p>(5) The left figure means 2<sup>nd</sup> point calibration weight.</p>
	<p>(6) The left figure shows 3<sup>rd</sup> point calibration weight</p>
	<p>(7) The left figure shows "1div equals 33 internal counts". The 1div of scale1 is always around 33. The one of scale2 should be close to 33. If not, adjust AP-10 to make the 1div of scale2 close to 33 as could as possible.</p> <p>For example: TC 30kgx1g 1g=33 internal counts</p>
<p>Note:  means that we are checking the calibration data under the main scale mode.</p>	

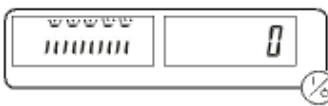
■ Set AD Gain Of Remote Platform

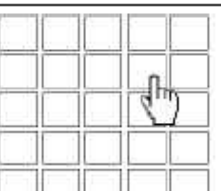
	<p>(1) Under normal weighing mode, press  for 3 seconds to enter the basic parameter settings.</p>
	<p>(2) The scale is now in the basic parameter setting mode. press  for 3 seconds to enter the advance parameter settings.</p>
	<p>(3) The scale is now in the advance parameter setting mode.</p>
	<p>(4) Press  or  to switch between the parameters. Repeat step 3 until AP-10 appear in the weight display, as show in the left chart below.</p>
	<p>Note: This ad value should make 1div of scale2 close to 33.</p>
	<p>(5) Press  or  to select proper AD gain</p> <p>Note : There are 8 options of ad gain 1,2,4,8,16,32,64.</p>
	<p>(6) Press  or  to save and go to next advanced parameter setting or press  to save the setting and return to normal weighing mode.</p>

■ How To Switch Between Main Scale And Remote Platform

  <p>Main scale Capacity: 30kg Division: 1g</p>	  <p>Second platform Capacity: 300 kg Division: 10g</p>
  	<p>(1) In this example the scale is in the main scale mode. To switch to the sub channel mode (second platform), press </p>
 	<p>(2) The 55555 flashed in the weight display..</p>
 	<p>(3) When 55555 flashing disappear, means that you are in the sub channel mode (second platform). Now the second platform could be used, and all applications of TC plus could be used.</p>
  	<p>(4) To change back to the main scale mode just press , and 100000 will flash in weight display</p>
 	<p>(5) When 100000 flashing disappear, means that the scale have returned back to main scale mode. All applications is of course available in this mode also.</p>

**Some restriction in dual channel system**

Accumulation

When accumulated already in one channel, it can't be accumulated in another channel.

Hi/Lo checking

When Hi/Lo checking is enable in one channel, Hi/Lo setting can't be accessed and enabled in another channel.

## CHAPTER 4 MAINTENANCE

### 4-1 Replacing printed circuit board

**Note ! : To proceed cautiously & carefully**

*Any intention to replace PCB and/or to repair components  
on the board must proceed cautiously and carefully;  
otherwise further irreversible damage(s) may be caused.*

There are two PCBs in the scale. One is the **A/D & power PCB**, and the other is **display PCB**. The **A/D & power PCB** is mounted horizontally at the bottom. And **display PCB** is one containing LCD and keypads. Follow the procedure below to replace PCB.

1. Switch off the scale.
2. Remove the stainless steel weighing pan. Loosen and remove the four fixing screws on the plastic weighing pan. Refer to the picture at the down left. (TC series counting scale is illustrated here.)
3. Remove the plastic weighing pan. Refer to the picture at the down right. (This step **must be done prior to** turn the scale up side down. Otherwise, the load cell may sustain unexpected force that may cause irreversible damage to the load cell.)



4. Slide out and remove the battery box (to work with two hands suggested), and then the option device module (to work with single hands suggested.) Refer to the pictures below.



5. Turn up side down the scale. Loosen and remove the two fixing screws on the plate covering the battery box and the option module. Refer to the picture below.



6. Loosen and remove the four fixing screws on the bottom cover. Refer to the pictures below.



7. At lateral side of the scale body, about 10cm from the rear, press the lower cover toward the inner to open the upper and the lower covers. To do this at both right and left lateral. Refer to the pictures below. Remove the upper cover.



8. Place the scale like shown below for further maintenance work.



9. *If to replace display PCB is intended.* Dismount every connector from the board first. Then, lift carefully the PCB out of its mounted position.
10. *If to replace A/D & power PCB is intended.* The display PCB should be dismantled first. Afterwards, dismount every connector from the A/D & power PCB. Followed by using soldering iron to remove the load cell wires, “GND” in yellow, “E+” in blue, “E-” in black, “S+” in white, and “S-” in red, from the board. Then, dismount and remove the two PCB fixing screws. (**Pay attention that** there is one fixing screw with the green grounding wire with it.) Then lift the PCB out. Refer to the pictures below.



11. Prepare a new PCB.
12. *If to replace A/D & power PCB.* Solder load cell wires, “GND” in yellow, “E+” in blue, “E-” in black, “S+” in white, and “S-” in red, to the new board. Followed by installing the PCB back to its mounted position with the two fixing screws. (**Pay attention that** there is one fixing screw with the green grounding wire with it.) Then, install every connector to the new board.
13. *If to replace display PCB.* Install every connector to the new board. Followed by installing the PCB back to its mounted position with hands.
14. Work backward from the step 2 to the step 8 to install the upper cover, battery and option covering plate, battery box & option module, and weighing pan, respectively. (**Note that** the direction of arrow sign on the plastic weighing pan should be pointing to the LCD side.)
15. Switch on the scale to check.
16. To enter the in-house service mode to set the model (refer to Section 2-3.)
17. To conduct calibration (refer to Section 2-1).

## 4-2 Replacing load cell

1. Switch off the scale.
2. Follow **the steps 2 to steps 8** in the previous Section to prepare the scale.
3. Use soldering iron to remove the load cell wires, “**GND**” in yellow, “**E+**” in blue, “**E-**” in black, “**S+**” in white, and “**S-**” in red, from the A/D & power PCB. (If it is needed, dismount display PCB first, for soldering iron to access the A/D & power PCB.)
4. Rotate with hands the four support feet on the bottom of the scale to dismount them.
5. Loosen and remove the four round-headed screws that fix the load cell lower supporter to the scale lower cover. Dismount the green grounding wire connected to A/D & power PCB.
6. Lift the whole load cell supporter module out of the scale.
7. On the load cell supporter module, loosen and remove the four hexagonal socket screws, two respectively on the upper and lower supporter, for taking the load cell out.
8. Prepare and install a new load cell to the load cell supporter module. Install the four hexagonal socket screws that fix the load cell. (**Do not fully tighten** the four hexagonal socket screws for the moment.) Align the upper and lower load cell supporters vertically first. (A simple way doing alignment is that by inserting **diagonally** two tools, such as screwdrivers, respectively into the holes at the load cell supporter (indicated by arrow on the diagram above.) Afterwards, tighten the four hexagonal socket screws that fix the load cell.
9. Put the whole load cell supporter module into the scale.
10. Install the four support feet on the bottom of the scale.
11. Install the four round-headed screws that fix the load cell lower supporter to the scale lower cover. Install the green grounding wire connected to A/D & power PCB.
12. Solder the load cell wires, “**GND**” in yellow, “**E+**” in blue, “**E-**” in black, “**S+**” in white, and “**S-**” in red, to the A/D & power PCB.
13. Work backward to install the upper cover, battery and option covering plate, battery box & option module, and weighing pan, respectively. (**Note that** the direction of arrow sign on the plastic weighing pan should be pointing to the LCD side.)
14. Switch on the scale to check.
15. Conduct calibration (refer to Section 2-1), then to check weighing functions.

## CHAPTER 5 TROUBLESHOOTING

### 5-1 Preliminary checks

1. Is the bubble of the level indicator at the center?
2. Is the battery electricity capacity OK?
3. Is AC power cord correctly plugged?
4. Is the weighing pan the right one?
5. Is there anything under the weighing pan?
6. Is the scale at a flat and steady base?
7. Are there any vibrating, rotating, and/or reciprocating equipment around?
8. Is there any air turbulence within the environment?
9. Is there any equipment that generates magnetic field around?
10. Is there rapid temperature change within the environment?
11. Are there any cooling and/or heating sources around?





### 5-2 Error messages







Error Messages Shown	Error Status
<i>E UnSt</i>	Unstable status in initial state
<i>PHi</i>	Initial zero range > 10%
<i>PLo</i>	Initial zero range < -10%
<i>E noEE</i>	Memory device EEPROM malfunction
<i>E CALF</i>	Error in calibration parameter
-----	Weight load over the maximum indication, i.e., Max. Capacity + 9e
<i>CLF-b</i>	Low voltage at RTC (real time clock) battery
<i>d1 FFE</i>	Trial made to mix accumulation with net weight and net weight with quantity
<i>ou-15</i>	The previous accumulation is over the preset accumulation allowed

## 5-3 Problems and solutions

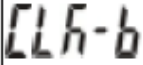
**Note ! :**

*Any intention to replace PCB and/or to repair components on the board must proceed cautiously and carefully; otherwise further irreversible damage(s) may be caused.*

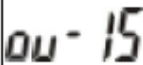
Problems	Possible Causes	Solutions
No any function pressing ON/OFF switch to turn on	<ol style="list-style-type: none"> <li>1. Malfunction in ON/OFF switch</li> <li>2. Power socket fuse burn down</li> <li>3. POWER &amp; A/D PCB "F1" fuse burn down</li> <li>4. Lead-acid battery low capacity</li> <li>5. Malfunction in A/D &amp; POWER PCB</li> <li>6. Bad soldering at U3 of DISPLAY CONTROL PCB</li> <li>7. Malfunction in transformer</li> </ol>	<ol style="list-style-type: none"> <li>1. Check/Replace ON/OFF switch</li> <li>2. Replace the power socket fuse</li> <li>3. Replace the "F1"fuse on POWER &amp; A/D PCB</li> <li>4. Recharge the lead-acid battery, or replace it</li> <li>5. Check/Replace A/D &amp; POWER PCB</li> <li>6. Re-solder U3 of DISPLAY CONTROL PCB</li> <li>7. Check/Replace transformer</li> </ol>
Shown error message 	<ol style="list-style-type: none"> <li>1. Initial ZERO range above upper limit</li> <li>2. Malfunction in load cell</li> <li>3. Malfunction in POWER &amp; A/D PCB</li> </ol>	<ol style="list-style-type: none"> <li>1. Check whether there is any object onto the weighing pan. Re-conduct calibration, refer to Section 3-1.</li> <li>2. Check/Replace load cell</li> <li>3. Check/Replace POWER &amp; A/D PCB</li> </ol>
Shown error message 	<ol style="list-style-type: none"> <li>1. Initial ZERO range below lower limit</li> <li>2. Malfunction in load cell</li> <li>3. Malfunction in POWER &amp; A/D PCB</li> </ol>	<ol style="list-style-type: none"> <li>1. Re-conduct calibration, refer to Section 3-1.</li> <li>2. Check/replace load cell</li> <li>3. Check/replace POWER &amp; A/D PCB</li> </ol>
Shown error message 	<ol style="list-style-type: none"> <li>1. Malfunction at U13 (EEPROM) of DISPLAY CONTROL PCB</li> </ol>	<ol style="list-style-type: none"> <li>1. Replace U13 (EEPROM) of DISPLAY CONTROL PCB</li> <li>2. Re-conduct setting, refer to User Manual Chapter 3 SETTING MODE</li> </ol>
Shown error message 	<ol style="list-style-type: none"> <li>1. Mistake made in calibration parameters</li> </ol>	<ol style="list-style-type: none"> <li>1. Conduct calibration, refer to User Manual "3-POINTS CALIBRATION MODE"</li> </ol>
Shown error message 	<ol style="list-style-type: none"> <li>1. Weight load over max capacity + 9e</li> </ol>	<ol style="list-style-type: none"> <li>1. Reduce weight load, or remove it</li> </ol>

Shown error message 	<ol style="list-style-type: none"> <li>1. Unstable ZERO when switching on</li> <li>2. Malfunction in load cell</li> <li>3. Malfunction in POWER &amp; A/D PCB</li> </ol>	<ol style="list-style-type: none"> <li>1. Make sure the environment is not interfered, such as air turbulence, vibration, and/or reciprocating equipment around. If interference factor is un-avoidable, try to alter parameter AP-2 setting, such as from "3-15" to "3-30".</li> <li>2. Change/Replace load cell</li> <li>3. Replace POWER &amp; A/D PCB</li> </ol>
Shown error message 	<ol style="list-style-type: none"> <li>1. RTC (real-time-clock) battery low capacity</li> </ol>	<ol style="list-style-type: none"> <li>1. Replace RTC (real-time-clock) battery</li> </ol>
Shown error message 	<ol style="list-style-type: none"> <li>1. Trial made to mix accumulation with net weight and net weight with quantity</li> </ol>	<ol style="list-style-type: none"> <li>1. Press  key twice to clear all the accumulation, or press  key to return to the normal weighing mode</li> </ol>
Shown error message 	<ol style="list-style-type: none"> <li>1. The previous accumulation is over the preset accumulation allowed</li> </ol>	<ol style="list-style-type: none"> <li>1. Press  key twice to clear all the accumulation, or press  key to return to the normal weighing mode</li> </ol>
Some segments of LCD are missing	<ol style="list-style-type: none"> <li>1. Bad contact in LCD conductive rubber of DISPLAY CONTROL PCB</li> <li>2. Bad soldering at U3 of DISPLAY CONTROL PCB</li> </ol>	<ol style="list-style-type: none"> <li>1. Loosen and then reinstall LCD fixing frame of DISPLAY CONTROL PCB</li> <li>2. Re-solder U3 of DISPLAY CONTROL PCB</li> </ol>
'CHARGE' LED no indication	<ol style="list-style-type: none"> <li>1. Power socket fuse burn down</li> <li>2. POWER &amp; A/D PCB "F1" fuse burn down</li> <li>3. Malfunction in "D4" of DISPLAY CONTROL PCB</li> <li>4. Malfunction in POWER &amp; A/D PCB</li> <li>5. Malfunction in transformer</li> </ol>	<ol style="list-style-type: none"> <li>1. Replace the power socket fuse</li> <li>2. Replace the "F1" fuse on POWER &amp; A/D PCB</li> <li>3. Replace "D4" of DISPLAY CONTROL PCB</li> <li>4. Replace POWER &amp; A/D PCB</li> <li>5. Replace the transformer</li> </ol>
Unable to charge lead-acid battery to full capacity	<ol style="list-style-type: none"> <li>1. Lead-acid battery over discharged</li> <li>2. Error in power supply voltage setting</li> </ol>	<ol style="list-style-type: none"> <li>1. Replace lead-acid battery</li> <li>2. Alter power supply voltage setting</li> </ol>

<p>LCD back-light no function</p>	<ol style="list-style-type: none"> <li>1. Mistake in back-light parameter setting</li> <li>2. Malfunction in "U16" of DISPLAY CONTROL PCB</li> </ol>	<ol style="list-style-type: none"> <li>1. Set again the backlight parameter; refer to User Manual.</li> <li>2. Change "U16" of DISPLAY CONTROL PCB</li> </ol>
<p>Inaccurate weighing</p>	<ol style="list-style-type: none"> <li>1. Delivery protection screw is locked</li> <li>2. Mistake in calibration parameter setting</li> <li>3. Malfunction in load cell</li> </ol>	<ol style="list-style-type: none"> <li>1. At the bottom, loosen counter-clockwise the protection screw to the end</li> <li>2. Re-calibrate; refer to Section 2-1.</li> <li>3. Check/Replace load cell</li> </ol>

## CHAPTER 6 SPARE PARTS & ACCESSORIES

### 6-1 TC series

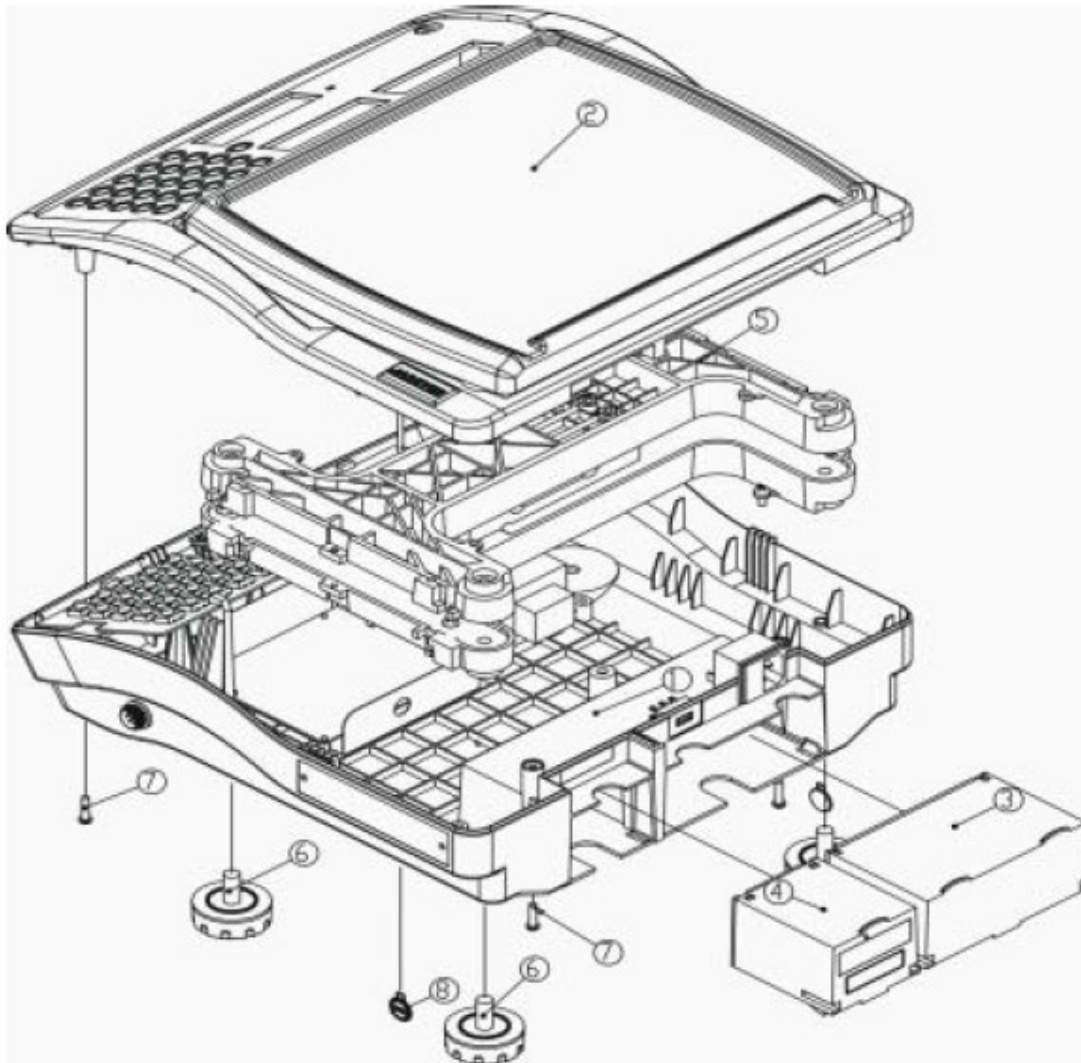

#### · TC Series

Item	Part No.	Part Name / Description		Quantity
1	91-5000-0120	Bottom Cover Assy.	下組合	1
2	91-5000-0110	Upper Cover Assy.	上組合	1
3	83-1000-0100	Battery Cassette	電池盒	1
4	83-1000-1100	Option Cassette	選配盒	1
5	91-5000-0130	AI. Supporter Assy.	鋁支架組合	1
6	01-0100-0006	Adjustable Foot	• • • • •	4
7	30-0601-0003	Self-Tapping Screw	• • • • • • • •	4
8	-----	Sealing Lead	封鉛	2

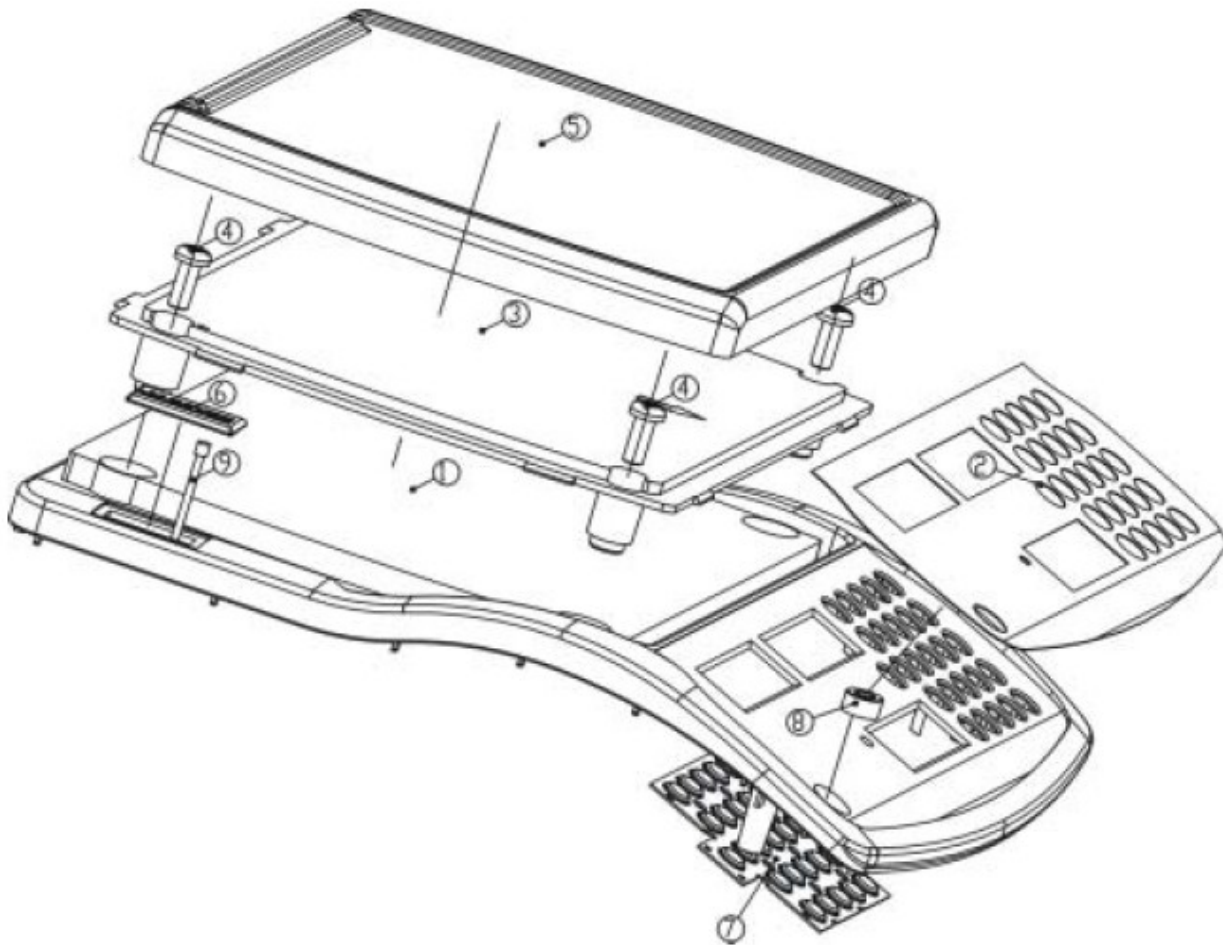

· Upper Cover Assy.

Item	Part No.	Part Name / Description		Quantity
1	02-0000-1000	Upper Housing – Counting scale	上蓋 計數秤	1
	02-0000-1001	Upper Housing – Weighing scale	上蓋 計重秤	
2	20-0904-0200	Front Panel Sheet (TC-200&TC-220)	前板	1
	20-0904-1200	Front Panel Sheet (TC-210)	前板	
	20-0904-2200	Front Panel Sheet (TC-290&TC-292)	前板	
3	02-0000-1020	Plastic Weighing Pan	• • • • •	1
4	30-0203-0100	Round Head Screw	丸頭螺絲	4
5	12-0000-0600	SS Weighing Pan	不銹鋼秤盤	1
6	22-0201-0000	Name Plate (No Logo )	• • • • •	2
7	21-0505-0000	Keyboard	按鍵	1
8	02-0108-0002	Level Indicator (Write)	水平儀	1
	02-0108-0010	Level Indicator ( 6kg)	水平儀 – 6kg	
9	31-0402-0200	Seal Supporter	封鉛銅桿	2

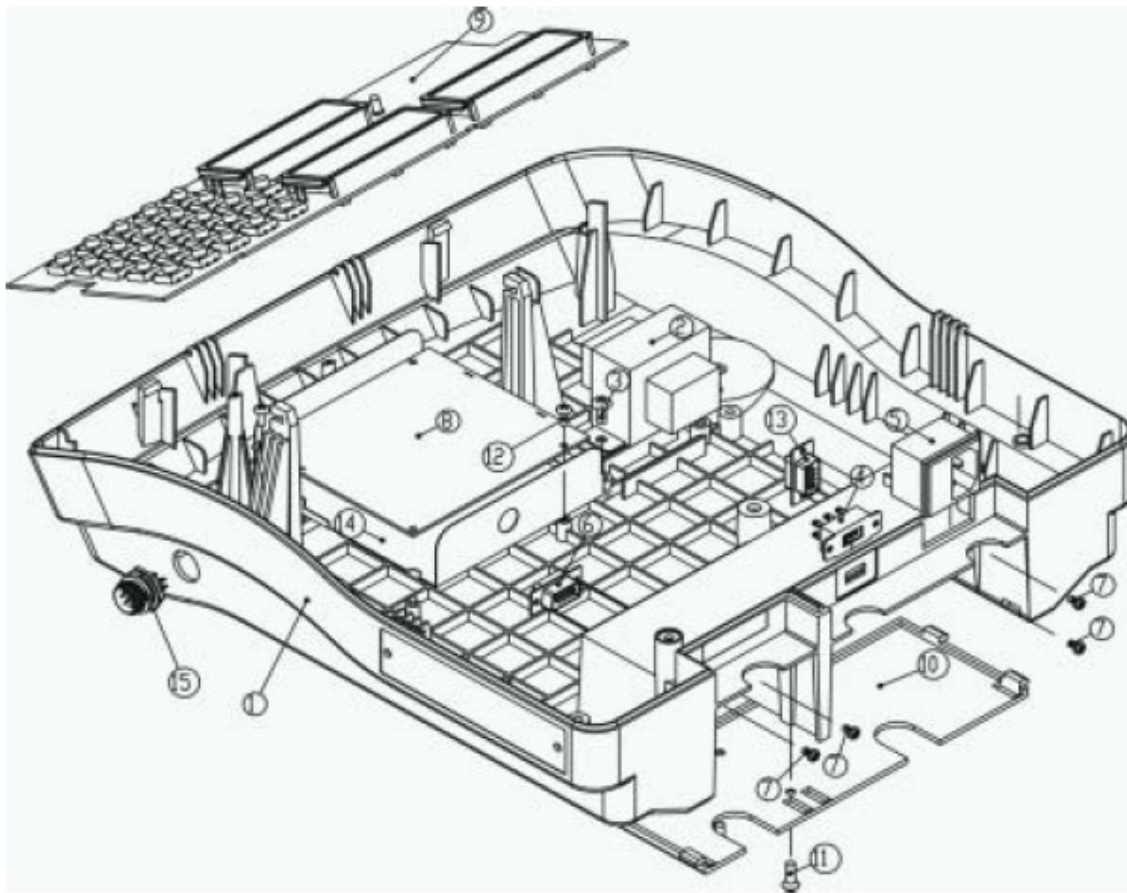

· Bottom Cover Assy.

Item	Part No.	Part Name / Description	Quantity
1	02-0000-1010	Bottom Housing	1
2	61-0003-0200	Transformer	1
3	30-0300-0003	Button Head Screw	2
4	60-0100-0000	Slide Switch (110V-220V)	1
5	60-0503-0001	Power Socket	1
6	61-0421-0000	D-Type Connector	1
7	30-0204-0100	Round Head Screw	4
8	80-0130-0101	A/D PCB Assy. (TC-200&TC-210&TC-290)	1
	80-0130-0400	A/D PCB Assy. (TC-220&TC-292)	
9	80-0130-0001	Display PCB Assy. (CPU excluded) (TC-200&TC-220&TC-290&TC-292)	1
	80-0130-0201	Display PCB Assy. (TC-210)	
10	02-0000-1030	Plastic Fixed plate	1
11	30-0601-0100	Self-Tapping Screw	2
12	30-0602-0001	Self-Tapping Screw	2
13	61-0421-0001	D-Type Connector	1
14	11-0604-0200	EMS plate	1
15	60-0402-0200	Connector ( Dual )	1

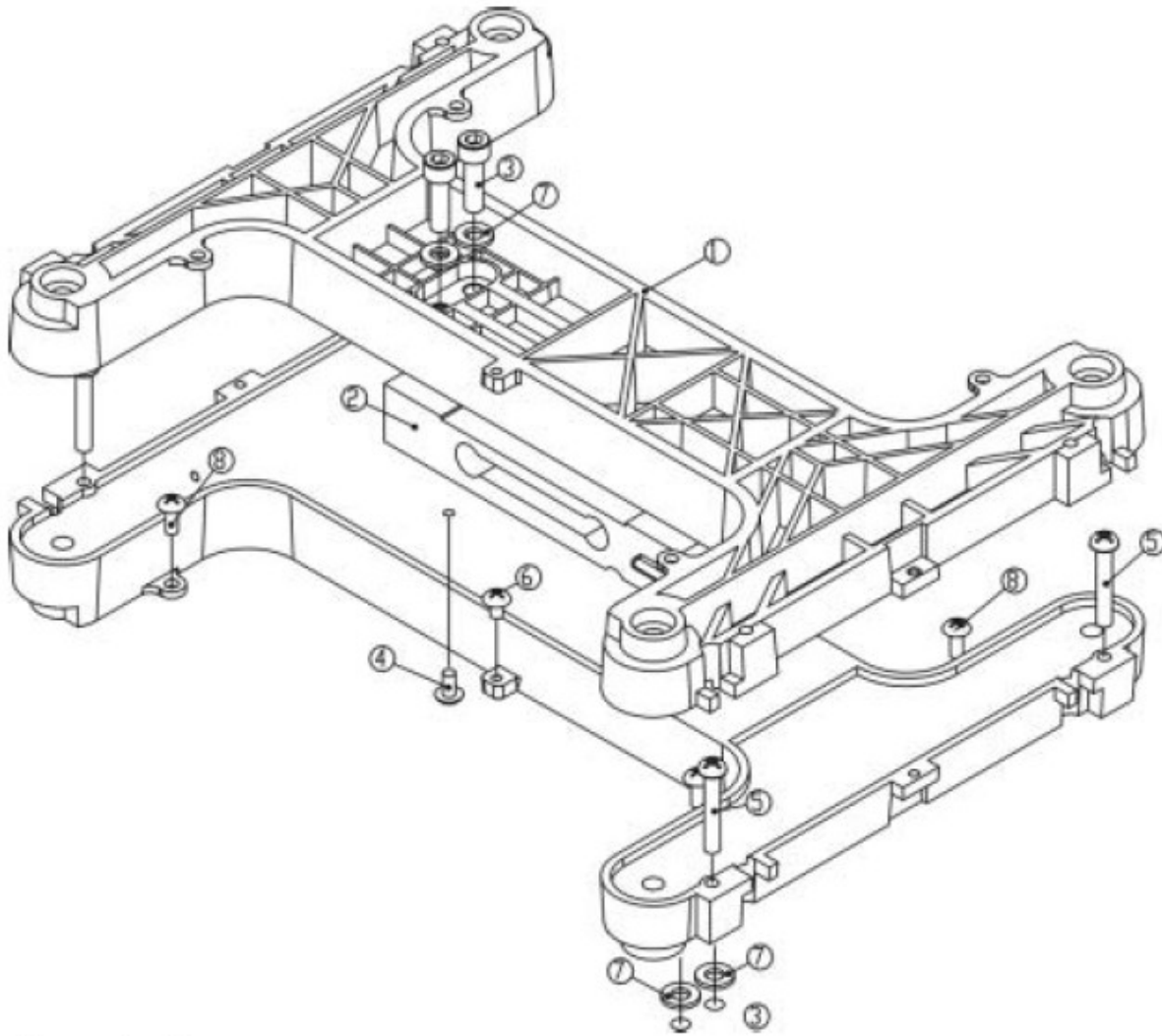

· AI. Supporter Assy.

Item	Part No.	Part Name / Description		Quantity
1	10-0404-0100	Upper AI. Supporter (6kg & 15kg)	鋁合金上支架	2
	10-0404-0200	AI. Supporter	鋁合金支架	
2	51-0015-0200	Load Cell – 6K TEDEA	傳感器	1
	51-0015-0300	Load Cell – 15K TEDEA		
	51-0015-0000	Load Cell – 30K TEDEA		
3	30-0000-0007	Hex Socket Screw	內六角螺絲	4
4	30-0300-0005	Transport Protector Screw	運送保護螺絲	1
5	30-0200-0200	Over Load Protector Screw	過載保護螺絲	4
	30-0400-0010	Over Load Protector Screw 6kg&15kg	過載保護螺絲	
6	30-0300-0001	Button Head Screw	大扁圓頭螺絲	1
7	31-0001-0000	Washer	華司	4
8	30-0300-0003	Button Head Screw	大扁圓頭螺絲	4

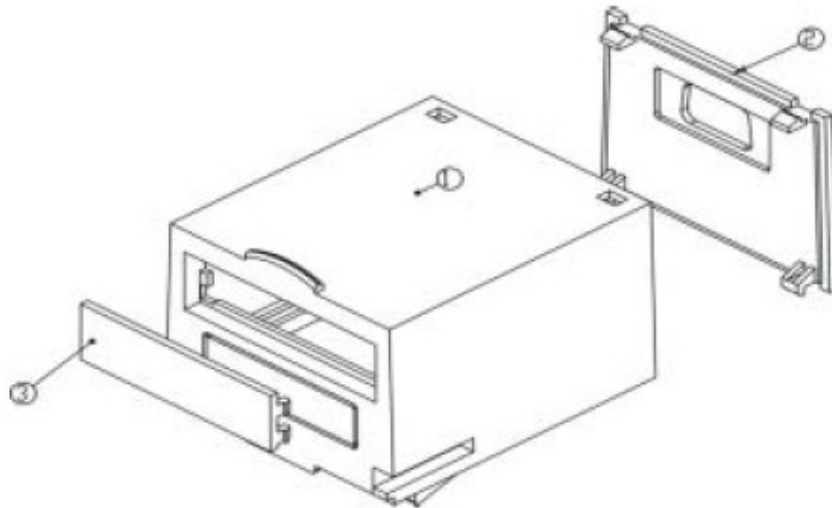

· Option Cassette

Item	Part No.	Part Name / Description		Quantity
1	02-0000-1060	Option Box (RS-232 & Relay)	選配盒	1
2	02-0000-1070	Box Rear Plate	選配盒後蓋	1
3	02-0000-1080	Box Front plate	選配盒前板	1

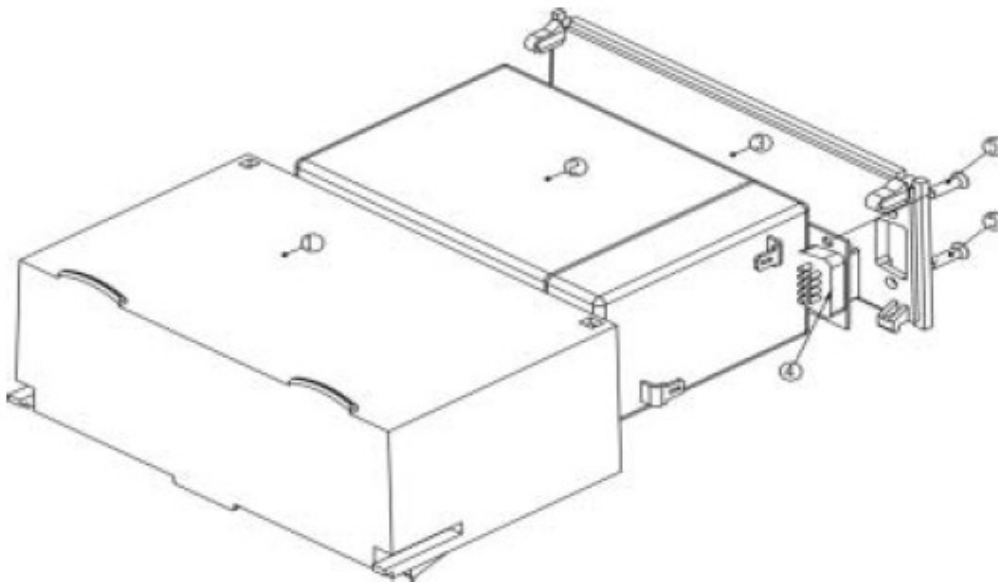

· Battery Cassette

Item	Part No.	Part Name / Description		Quantity
1	02-0000-1040	Battery Box	電池盒	1
2	61-0202-0000	Rechargeable Battery	充電電池	1
3	02-0000-1050	Battery Cover	電池蓋	1
4	61-0421-1000	D-Type Connector	D 型連接器	1
5	30-0402-0000	Button Head Screw	大扁螺絲	2

*13-01 Pollitt Drive*

*Fair Lawn, NJ 07410, USA*

*Email: [sales@totalcomp.com](mailto:sales@totalcomp.com)*

 **Totalcomp, Inc.**

the weigh you want... *today!*

*Phone 800-631-0347 / 201-797-2718*

*Fax 888-797-2288 / 201-797-2287*